

THIS DRAWING IS UNPUBLISHED. RELEASED FOR PUBLICATION
 © COPYRIGHT BY TYCO ELECTRONICS CORPORATION. ALL RIGHTS RESERVED.

LOC		DIST		REVISIONS			
P	LTR	DESCRIPTION	DATE	DWN	APVD		
DF	DO	T	REV PER ECO 07-025060	10-29-07	CT	BW	

WHEN ORDERING CONTACT ON TAPE, ORDER BY THE TAPE NUMBER PLUS THE PACKAGING CODE AS FOLLOWS:

2. FOR USE WITH AMP TAPETRONIC, PNEUMATIC TOOL-
 - A. 1000 PARTS TO A BOX ADD PACKAGING CODE: 1MBOX
3. FOR USE WITH 4/8 INDENT STRIPPER CRIMP-
 - A. 1000 PARTS TO A REEL ADD PACKAGING CODE: 1MREEL
 - B. 5000 PARTS TO A REEL ADD PACKAGING CODE: 5MREEL

- 1 MATERIAL: COPPER ALLOY PER MIL-C-39029 & MIL-DTL-24308.
- 2 ALL DIMENSIONS APPLY AFTER PLATING.
- 3 THIS DRAWING COMPLIES WITH SPECIFICATION MIL-C-39029/64 & M24308/11-1.
- 4 ALL DIAMETERS CONCENTRIC WITH EACH OTHER WITHIN .004 T.I.R.
- 5 PIN MATES WITH SOCKET 205090 (MIL-C-39029/63).
- 6 ALL SURFACES HAVE $\sqrt{63}$ OR BETTER FINISH, UNLESS SHOWN.
- 7 POINT OF PLATING MEASUREMENT .188 [4.78] FROM TIP OF PIN.
- 8 PLATING: GOLD PER ASTM-B-488 (TYPEII) OVER NICKEL PER QQ-N-290.
- 9 PLATING: GOLD PER ASTM-B-488 (TYPEII) OVER COPPER PER MIL-C-14550, CLASS 4.
- 10 PLATING: GOLD PER ASTM-B-488 (TYPE II, CLASS 0) OVER NICKEL PER QQ-N-290.

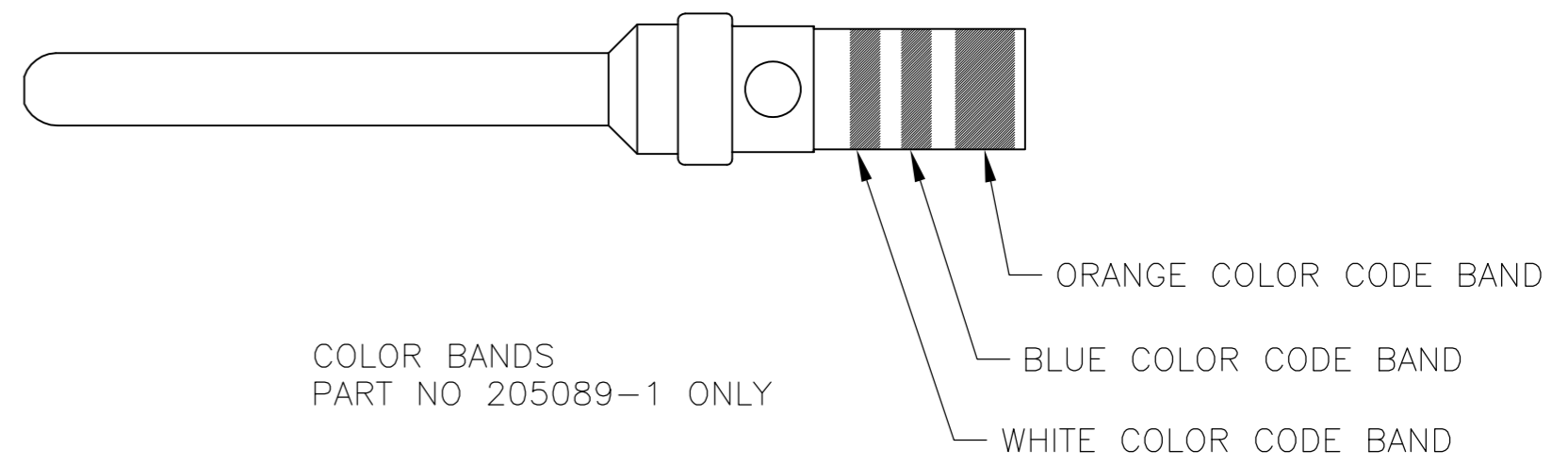
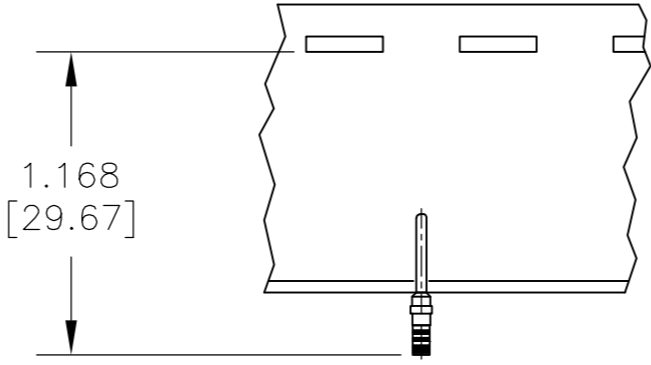
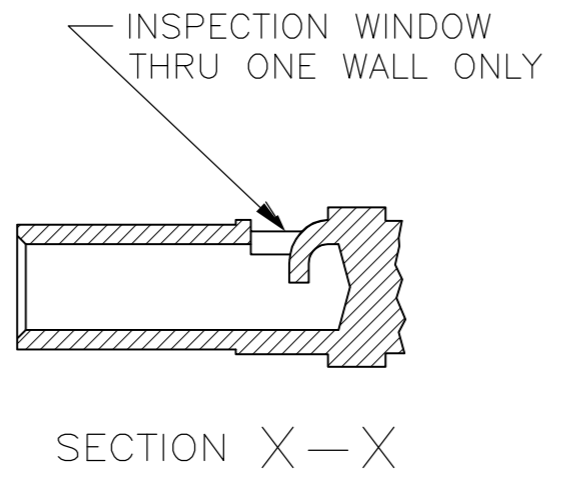
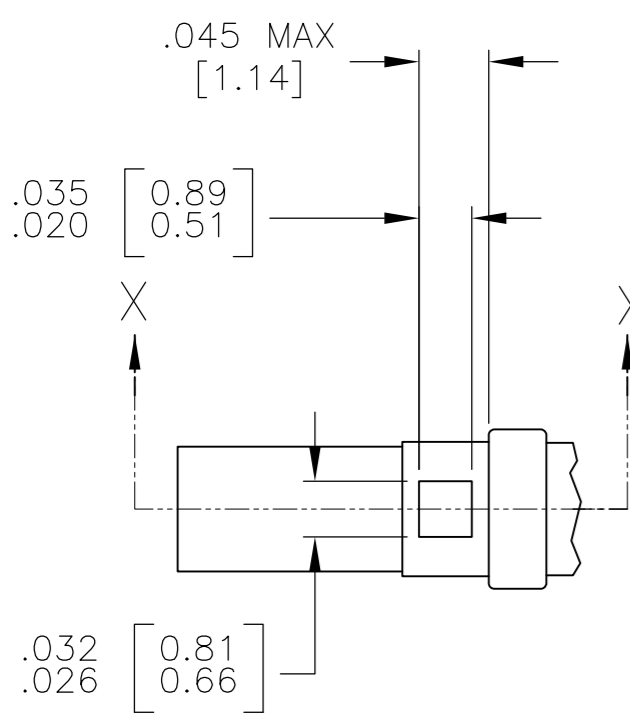
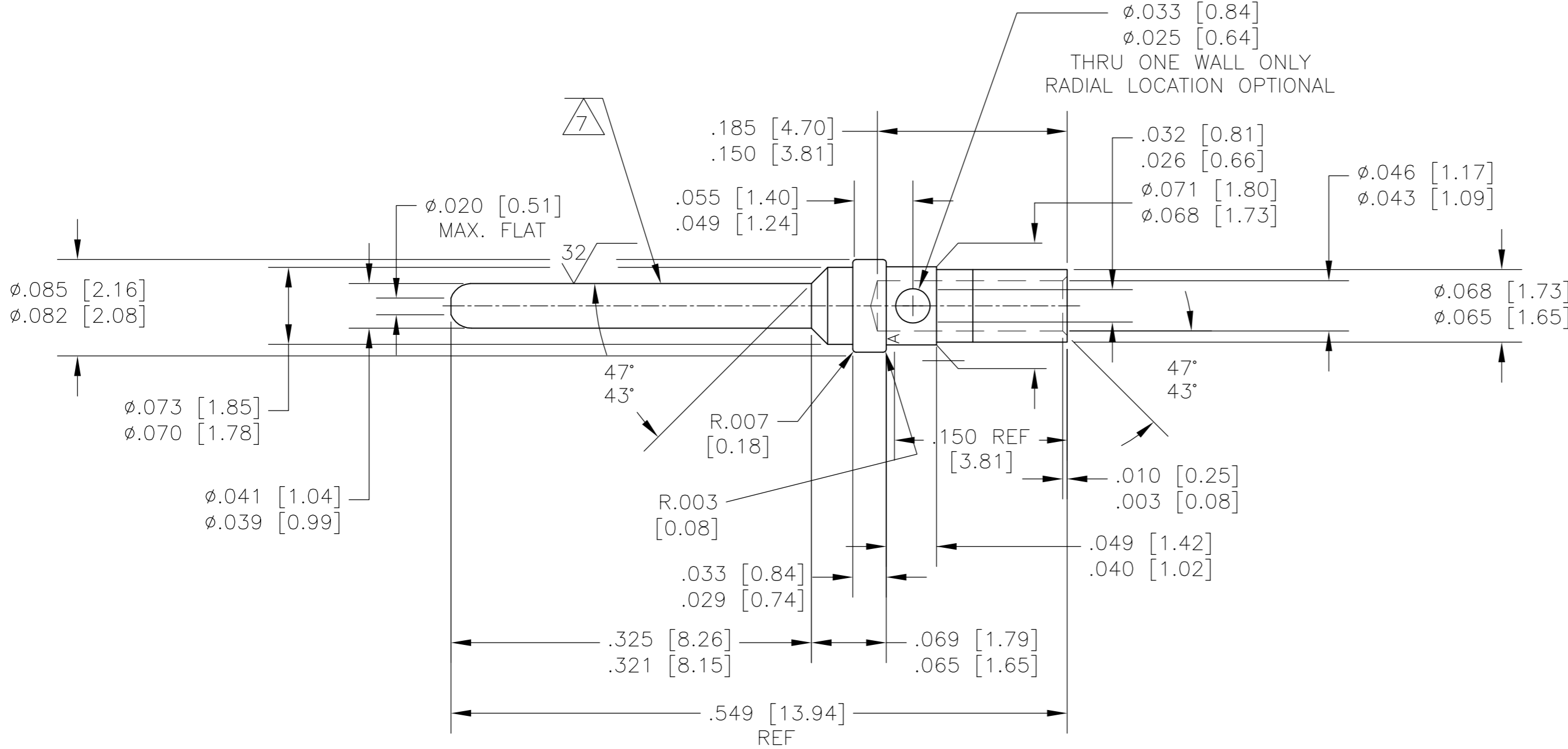

INSPECTION WINDOW OPTIONAL DESIGN $\triangle 16$

WITHOUT COLOR CODE	$\triangle 8$	1-205089-1
WITHOUT COLOR CODE	$\triangle 10$	1-205089-0
WITHOUT COLOR CODE	$\triangle 9$	205089-4
CONTACT ON TAPE	SAME AS -1	205089-2
AS SHOWN	$\triangle 8$	205089-1
DESCRIPTION	PLATING	PART NO.

THIS DRAWING IS A CONTROLLED DOCUMENT.		DWN	25AUG2003		Tyco Electronics Corporation	
DIMENSIONS: INCHES		CHK	J. KAISER		Harrisburg, PA 17105-3608	
TOLERANCES UNLESS OTHERWISE SPECIFIED:		APVD	D. MILLER		NAME	
0 PLC ± -		PRODUCT SPEC	D. MILLER		PIN SIZE 20 CONTACT, AMPLIMITE	
1 PLC ± -		APPLICATION SPEC	10-13-03		SIZE	
2 PLC ± -		WEIGHT	-		CAGE CODE	
3 PLC ± -		CUSTOMER DRAWING	-		DRAWING NO	
4 PLC ± -		SCALE	10:1		SHEET	
ANGLES ± -		RESTRICTED TO	-		1 OF 1	
FINISH		REV	T			
$\triangle 1$						